

PRINTING BASICS

Simple Booth apps support printing over AirPrint, a wireless printing protocol by Apple. Most new consumer printers support AirPrint, but make sure to double-check that a printer specifically supports AirPrint and not just wireless printing in general. For example, even some expensive Hiti printers are "wireless-enabled" but not AirPrint compatible (as of 4/2015).

TURN ON PRINTING

In the iPhone version, printing is automatically turned on for 4x6 prints and there are no settings to change it. In the iPad apps, printing is turned off by default. To turn it on, open the app and scroll to the **SEND OPTIONS** panel. At the bottom right is the switch for the **PRINT BUTTON**. Tap it on and the **PRINTS** panel will appear. In Pro Edition 2 and HALO, there is an option for **AUTO PRINT**.

HOW OUR APPS PRINT

Simple Booth apps automatically format your layout for prints. The two primary functions that are automatically applied to print layouts are:

- 1) Rotate the layout 90 degrees if it will fit better on the specified paper size
- 2) Print two vertical photo strips on a single sheet if there is room

Simple Booth apps send a JPEG to the printer that is formatted based on your choice for paper size and padding. A JPEG does not include size information that is relevant to its placement on the page, so the actual placement on the page is up to the printer.

According to the AirPrint specifications, the photo sent to the printer should be centered on the sheet. If this is not the case then your printer, printer driver, or other software responsible for getting the print on the paper is placing it incorrectly and you should definitely complain to the printer manufacturer. However, our padding options should allow you to adjust it's placement anyway.

PRINT SETTINGS

Paper size

You should try to match the paper size in the app closely to the paper you've put in your printer for the best quality. The paper size is used to determine the resolution that is sent to the print and the area in which a photo layout can be placed. Specifically, the inches are multiplied by 300 DPI for the final pixel-based resolution sent to the printer.

Padding

Padding allows you to add blank space to the top, bottom, left or right of your JPEG. This can help you compensate if your printer is cutting off part of your photo or it is not aligned correctly. The blank space is either white or black, depending on your selection for the photo layout background color.

HOW TO PRINT TWO PHOTO STRIPS

Simple Booth apps will automatically arrange two vertical photo strips on a sheet if there is room. What is shown in the **PRINT PREVIEW** area in settings is the same as what is sent to the printer. If it is not printing two then try to make the strip taller or less wide, which can be accomplished by making sure you use settings such as:

- 1) Square crop or no crop in landscape orientation
- 2) Select the 1 by 4 photo strip layout
- 3) Place a logo on the strip

Any of these choices will make your layout taller so that two can fit side by side on a sheet. A 5x7 inch print will also give you proportionally more width to place two photo strips than a 4x6 would.

WIRELESS PRINTING

Certain features such as social sharing require an internet connection. In order to use such features, make sure that you have your printer setup on a Wi-Fi network that also has an internet connection.

Contrary to popular belief, not all Wi-fi networks are connected to the internet. Many printers come with what is called an “ad hoc” Wi-Fi network or “direct mode” that lets you connect to the printer without a router or hot spot. These networks generated by the printer do not have an internet connection. Your iPad can only connect to one Wi-Fi network at a time, so consult your printer’s user manual to set it up on a Wi-Fi network that is also connected to the internet. If you do not need social sharing or analytics, then you can just use an ad hoc network from your printer.

To manage the print queue from your iPad, double-tap the home button and slide all the way left while printing is in progress.

NETWORK TROUBLESHOOTING

Make sure your printer and iPad are on the same wireless band. Many routers provide a 2.4 ghz band, a 5 ghz band (or “media” band) and a guest network. They are effectively separate networks so pay attention to which one you select on each device and tell you iPad to “forget this network” for any that you do not intend to use so it does not switch without asking you.

If a printer does not show up on a network that it should be showing up on, try going to iPad’s settings, Wi-Fi, find the network and press “Forget this network.” Then re-add it using the network password.

RECOMMENDED CONSUMER PRINTERS

	Type	Print time	Notes
Canon Selphy CP1200 <small>*CP910 is the old version of this printer</small>	Mini dye-sub	1m 30s	Small and light, prints size close to 4x6
ZINK Happy Printer	Zero Ink	1m 15s	Stickers only. Maximum 2" width. Requires touch gesture to cut the strip
Epson PictureMate PM-400r	Inkjet	1m 15s	Prints 4x6 and 5x7. Easy paper loading

PROFESSIONAL PRINTING

Most professionals choose to use a high-end dye-sublimation printer for their speed and low cost-per-print. A good dye sublimation printer can print a 4x6 in less than 15 seconds! In order to use a professional dye-sublimation printer over AirPrint, you will need to install the printer's driver on a computer and use a print server application, which we have listed options for below.

Our best experience has been running Printopia on a MacBook Pro with a DNP DS40.

Below is a comparison guide to various third-party print server applications available on the internet:

	Operating System	Software Version	Printer	App Version	Issues
Printopia	Mac	2.1.10.3	DS40	PE2 v1.0.5	None
HandyPrint	Mac	5.1.1	DS40	PE2 v1.0.5	Application does not work with printer pre-selection feature.
Presto	PC	1.7.772	DS40	PE2 v1.0.5	Will not print full-bleed

More information on issues:

HandyPrint will not work as expected when you pre-select a printer in Simple Booth apps. You can refrain from pre-selecting a printer and it will work from the native iOS print dialog box, but if you pre-select it does not maintain a constant URL that the app can refer to for automatic printing.

Presto has an issue with leaving ¼” blank space at the top and bottom of every 4x6 print. 5x7 prints do not have this problem. You can prevent your images from getting cut off by using top and bottom padding in our app but it will still be empty space.

WPS-1

Pro Edition 2 and HALO apps support printing to the DNP WPS-1, a product from DNP that enables DNP printers to be accessed for wireless printing. It uses its own special protocol instead of AirPrint, so we have specially integrated with DNP.

Simple Booth apps will automatically detect the WPS-1 when on the Wi-Fi network generated by the WPS-1. It is very important to follow the procedures in the manual that comes with the WPS-1 when turning it on and plugging in the printer by USB.

Optional Router / Modem: The WPS-1 requires a hardwired ethernet connection to have internet access for social sharing. Plugging it into an ethernet online connection gives that same Wi-Fi network internet access, much like plugging a router into a modem. Printing only does not require internet access.

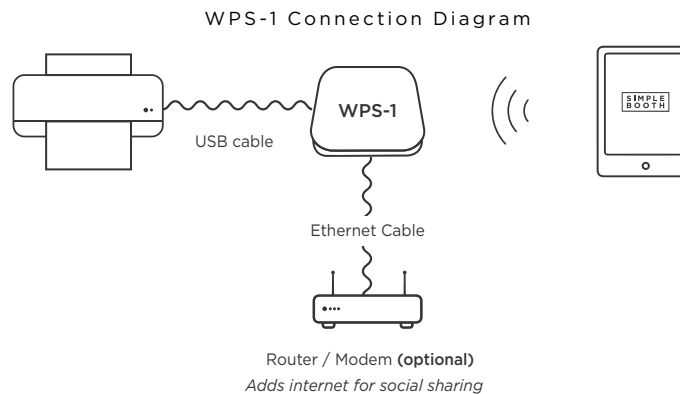

Contact us with any questions and our customer support will be glad to assist.

info@simplebooth.com



@simplebooth



@simplebooth



/simpleboothapp



/simpleboothapp